

MEDIUM VELOCITY GAS BURNERS

JMG-050
JMG-100
JMG-125
JMG-140
JMG-200

JMG-070
JMG-120
JMG-130
JMG-150

| GENERAL INFORMATIONS |

The "JMG" gas burner series is a blown-air burner which can operate with natural gas, LPG, lean gas and gas with low calorific power (on request). It was designed for the installation in all the process in which it is necessary to obtain a deeply oxidizing combustion to limit working temperature. The completely automatic working allows on-off regulations, high/low flame, air/gas modulating. The last allows to obtain max.-min. regulation ratio until 15:1. The maximum thermal potentiality is 2,675kW (2,300,000kcal/h) while the minimum potentiality can come up to 5.8kW(5,000kcal/h). Combustion air temperature required for this burner can change from room temperature until 300 °C. A particular care has been dedicated to CO and NOx emissions produced by combustion process, these elements are lower than limits required by EN 676 regulations. Burner structure is painting casting, the body is of iron, the bottom of aluminum, the parts in contact with flame of refractory steel and Nickel Chrome alloys. The burner has ignition and flame revelation electrodes, pressure switch to measure air and gas instantaneous flows, flame indicating light.

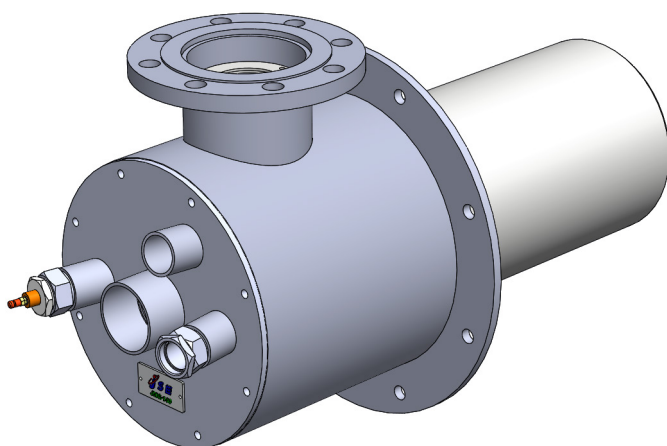

FEATURES

- Direct spark ignition, ionization flame detection electrode or U.V cell.
- For natural gas or LPG, other gaseous fuel on request.
- Max.-min. ratio 15:1.
- Available as complete version with gas ramp, according to EN 676 on right or left hand.
- Easy to install, to start, to operate.

APPLICATIONS

- All types of kilns, suitable for oxidative, stoichiometric or reducing combustion.
- Ceramic, Bricks, Refractory:
 - Roller kilns, Tunnel kilns, Intermittent kilns, Melting kilns.
 - Continuous and Intermittent Dryers.
- Iron metallurgic Industry.
- Surfaces Treatment.

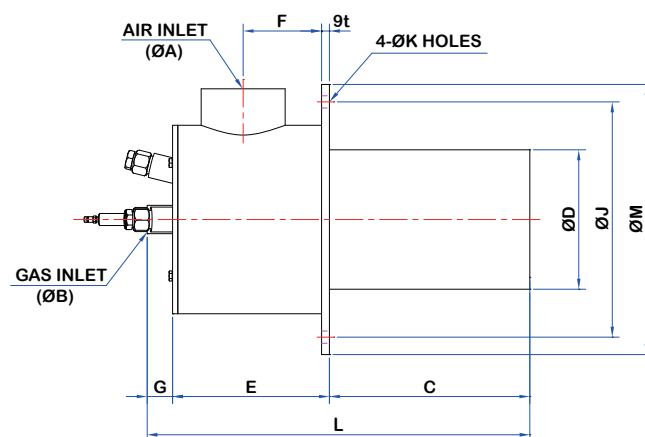
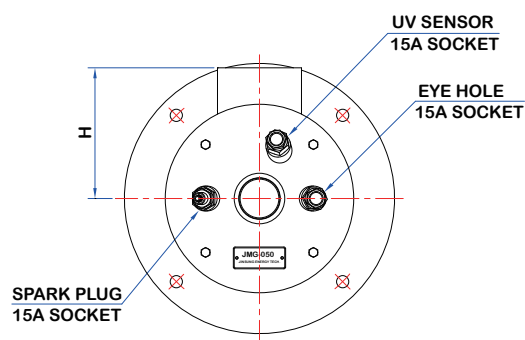

| DIMENSIONS |

MODEL	A	B	C	D	E	F	G	H	J	K	M	L
JMG-050	25A	20A	170	75	90	50	30	100	160	4-φ10	200	290
JMG-070	32A	25A	190	98	130	60	30	100	160	4-φ10	220	350
JMG-100	40A	25A	190	98	130	60	30	100	190	4-φ10	220	350
JMG-120	50A	32A	220	125	170	90	35	130	210	4-φ12	250	425
JMG-125	65A	40A	230	160	170	90	35	140	270	4-φ14	310	435
JMG-130	80A	40A	230	160	180	90	40	150	270	4-φ14	310	450
JMG-140	100A	50A	330	195	250	130	40	210	320	4-φ14	360	620
JMG-150	150A	65A	330	224	320	160	40	240	380	4-φ16	420	690
JMG-200	200A	80A	390	258	380	210	40	260	420	4-φ18	470	810

| TECHNICAL DATA |

MODEL	NOMINAL CAPACITY		AIR PRESSURE @15°C (mb)*	AIR VOLUME @15°C (Nm ³ /hr)	GAS PRESSURE (mb)*	MAXIMUM CAPACITY	
	(×10 ³ kcal/hr)	(kW)				(×10 ³ Kcal/hr)	(kW)
JMG-050	30	34	65	65	30	50	58
JMG-070	50	58	65	91	30	70	81
JMG-100	80	93	65	156	30	120	139
JMG-120	150	174	65	260	30	200	232
JMG-125	200	232	65	327	30	250	290
JMG-130	300	348	65	507	30	400	465
JMG-140	500	581	65	806	35	600	697
JMG-150	1,000	1,162	65	1,755	35	1,300	1,511
JMG-200	2,000	2,300	65	3,015	35	2,300	2,675

The above mentioned performance data are described at their maximum power.

Pressure showed are guidelines only.

Gas pressures are refer to Natural gas.

* Stoichiometric conditions.

Performance data and dimensions are guidelines only.

The descriptions and specifications are subject to change without notice.